

**TECHNICAL BULLETIN**

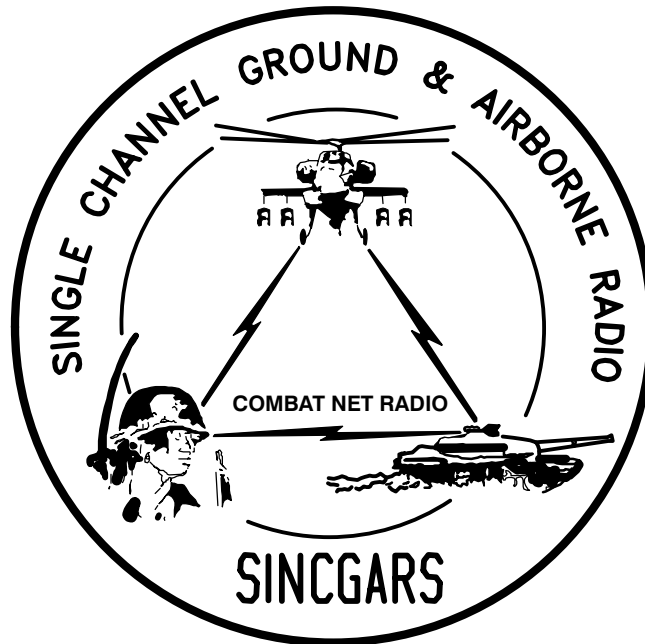

**INSTALLATION INSTRUCTIONS FOR  
INSTALLATION KIT, ELECTRONIC EQUIPMENT,  
MK-2373/VRC (NSN 5895-01-225-0513) (EIC: N/A)  
TO PERMIT INSTALLATION OF  
RADIO SET AN/VRC-87/88/90 SERIES  
IN A  
CARRIER, 107 MM MORTAR, FULL TRACKED, M106A1  
AND  
CARRIER, 81 MM MORTAR, FULL TRACKED, M125A1**

Approved for public release; distribution is unlimited.

DESTRUCTION NOTICE — Destroy by any method that will prevent disclosure of contents or reconstruction of the document.

---

**HEADQUARTERS, DEPARTMENT OF THE ARMY**

**1 AUGUST 1999**

**INSTALLATION INSTRUCTIONS FOR  
 INSTALLATION KIT, ELECTRONIC EQUIPMENT,  
 MK-2373/VRC (NSN 5895-01-225-0513) (EIC: N/A)  
 TO PERMIT INSTALLATION OF  
 RADIO SET AN/VRC-87/88/90 SERIES  
 INTO  
 CARRIER, 107 MM MORTAR, FULL TRACKED, M106A1  
 AND  
 CARRIER, 81 MM, MORTAR, FULL TRACKED, M125A1**

**REPORTING OF ERRORS AND RECOMMENDING IMPROVEMENTS**

You can help improve this manual. If you find any mistakes, or if you know of a way to improve the procedures, please let us know. Mail your letter, DA Form 2028 (Recommended Changes to Publications and Blank Forms) or DA 2028-2 located in back of this manual direct to: Commander, US Army Communications-Electronics Command Fort Monmouth, ATTN: AMSEL-LC-LEO-D-CS-CFO, Fort Monmouth, New Jersey 07703-5000. The Fax number is 732-532-1413, DSN 992-1413. You may also e-mail your recommendation to AMSEL-LC-LEO-PUBS-CHG@ce-com3.monmouth.army.mil.

In either case a reply will be furnished direct to you.

TABLE OF CONTENTS

Subject	Section	Page
Scope .....	0.1	1
General Information .....	0.2	1
Maintenance Forms, Records, and Reports .....	0.3	1
Reports of Maintenance and Unsatisfactory Equipment .....	0.3.1	1
Report of Packing and Handling Deficiencies .....	0.3.2	1
Discrepancy in Transportation Deficiency Report (TDR) (SF 361) .....	0.3.3	1
Consolidated Index of Army Publications .....	0.4	1
Purpose of Installation .....	1.	2
End Item or System to be Modified .....	2.	2
Application Times .....	3.	2
Time for Completion of Installation .....	3.1	2
Time for Installation of One Assembly or Component .....	3.2	2
Preparation for Installation .....	4.	2
Preparation of Vehicle .....	4.1	2
Preparation of MK .....	4.2	2
MK, Distribution, and Consumables .....	4.3	3
Tools and Test, Measurement, and Diagnostic Equipment (TMDE) Required .....	4.4	8
Installation Procedures .....	5.	9
Installation of Antenna AS-3916/VRC (antenna) .....	5.1	11
Installation of Antenna Base .....	5.1.1	11
Installation of Top Antenna Assembly .....	5.1.2	12
Installation of Electrical Equipment Shelf .....	5.2	13
Installation of Mounting Base, Electrical Equipment MT-6352/VRC (mounting base) .....	5.3	15
Installation of Cables .....	5.4	17
Post-Installation and Checkout .....	5.5	19
Appendix A. References .....		A1

\*This manual supersedes TB 11-5820-890-20-54, dated 1 September 1993.

LIST OF ILLUSTRATIONS

Figure	Title	Page
4-1	MK Illustrated Parts List .....	6
5-1(1)	MK and Radio Installation: MK Equipment Locations .....	9
5-1(2)	MK and Radio Installation: Radio Equipment Locations .....	10
5-2	Antenna Base Installation .....	11
5-3	Top Antenna Assembly Installation .....	12
5-4	Electrical Equipment Shelf Assembly and Installation .....	14
5-5	Mounting Base Installation .....	16
5-6	Cable Installation: Roadside Interior .....	18
5-7	Cable Diagram: For AN/VRC-87/88/90 Series .....	20

LIST OF TABLES

Number	Title	Page
4-1	Parts List for Installation of Radio Set AN/VRC-87/88/90 Series .....	4

## 0.1 SCOPE

This technical bulletin provides Installation Instructions for Installation Kit, Electronic Equipment, MK–2373/VRC, commonly referred to as the Mounting Kit (MK). The MK shall be installed into the following type of vehicle(s):

- Carrier, 107 MM Mortar, Full Tracked, M106A1
- Carrier, 81 MM Mortar, Full Tracked, M125A1

The MK is used for installation of radio set components at field locations. The information contained in this technical bulletin is the official authorization to perform the installation at the unit maintenance level.

### NOTES

- This technical bulletin is not an authorization for requisition or turn-in of vehicles.
- This technical bulletin does not establish quantity or types of vehicles assigned to using units.

This technical bulletin does not contain information on the maintenance or replacement of the MKs. This information is contained in the MAC of TM 11–5820–890–20–2 and RPSTL of TM 11–5820–890–20P.

## 0.2 GENERAL INFORMATION.

The MK becomes operable when all the radio set components are installed in the vehicle and correct power is supplied. Refer to TM 11–5820–890–20–1 or TM 11–5820–890–20–4 for installation, Operational (OP) Check instructions, and required maintenance procedures. Refer to TM 11–5820–890–20P for repair parts.

Included in the Radio Set AN/VRC–87/88/90 Series is:

- Radio Set AN/VRC–87/88/90 Series (for RT–1523(C)/U)

## 0.3 MAINTENANCE FORMS, RECORDS, AND REPORTS.

**0.3.1 Reports of Maintenance and Unsatisfactory Equipment.** See section 4.2.2.3 for information.

**0.3.2 Report of Packaging and Handling Deficiencies.** See section 4.2.2.1 for information.

**0.3.3 Discrepancy in Transportation Deficiency Report (TDR) (SF361).** See section 4.2.2.2 for information.

## 0.4 CONSOLIDATED INDEX OF ARMY PUBLICATIONS.

Refer to the latest issue of DA Pam 25–30 to determine whether there are new changes, or additional publications pertaining to the equipment.

**1. PURPOSE OF INSTALLATION.**

The Installation Kit, Electronic Equipment, MK–2373/VRC (MK) contains the items needed to mount Radio Set AN/VRC–87/88/90 Series in a Carrier, 107 MM Mortar, Full Tracked, M106A1 and Carrier, 81 MM Mortar, Full Tracked, M125A1 (vehicle).

**2. END ITEM OR SYSTEM TO BE MODIFIED.**

Not applicable.

**3. APPLICATION TIMES.**

**3.1 Time for Completion of Installation.** Using one person, a total of 3.5 work hours is required. Typical vehicle downtime is 4.0 hours.

**3.2 Time for Installation of One Assembly or Component.** The following table lists the time required to install one component. All times have been rounded off to the nearest half hour. The sum of these times will not reflect the typical vehicle downtime.

ITEM	SECTION	TIME
Antenna AS–3916/VRC	5.1	1.0
Mounting Base, Electrical Equipment MT–6352/VRC	5.3	1.5
Cables	5.4	1.0

**4. PREPARATION FOR INSTALLATION.**

This section explains how to prepare the vehicle and MK for installation.

**4.1 Preparation of Vehicle.** To prepare the vehicle for installation, insure that the site includes adequate lighting and a power source when drilling is required. Inspect the vehicle for damage that could affect installation. Have any such damage repaired before installing MK.

**4.1.1 Items to be Removed.** Remove existing AN/VRC–12 radio family installation kit/harness. See TM 11–5820–401–20–2 for removing items used with intercom systems, or TM 11–5820–401–20–1 (used without intercom systems), and TM 9–2350–261–20.

**4.1.2 List of Items to be Retained.** Not applicable.

**4.2 Preparation of MK.** To prepare MK, unpack, inspect and check inventory.

**4.2.1 Precautions During Handling.** Observe these steps to prevent equipment damage.

- a. Keep dust covers in place on connectors.
- b. Do not disassemble or modify parts in MK unless authorized to do so.
- c. Keep mounting hardware covered and protected until needed.
- d. When exposed to moisture, rain or salt water, keep all parts dry to prevent corrosion.

## **4.2.2 Unpack and Inspect Equipment.**

**4.2.2.1 Inspect Packaging for Evidence of Damage.** Any shipping damage should be reported on SF364 Report of Discrepancy (ROD) as prescribed in AR 735–11–2/DLAR 4140.55/NAVMATINST 4355.73A/AFR 400–64/MCO 4430.3F.

**4.2.2.2 Unpack and Inventory MK.** If any item is missing, fill out and forward Transportation Deficiency Report (TDR) (SF361) as described in AR 55–38/NAVSUPINST 4610.33C/AFR 75–18/MCO P4610.19D/DLAR 4500.15.

**4.2.2.3 Examine Each Item for Damage.** If any item is damaged, fill out and forward SF364 Report of Discrepancy (ROD) as prescribed in AR 735–11–2/DLAR 4140.55/NAVMATINST 4355.73A/AFR 400–64/MCO 4430.3F. All damages should be reported as prescribed by DA Pam 738–750, as contained in Maintenance Management Update.

## **4.3 MK, Distribution, and Consumables.**

**4.3.1 Items Supplied in MK and/or Required for Installation.** Use Table 4–1 and figure 4–1 to identify and inventory MK parts supplied to install Radio Set AN/VRC–87/88/90 Series.

### **4.3.2 Distribution and Issue Instructions.**

- a. US Forces: Do not requisition MK. They will be shipped automatically.
- b. US Army Depots: Requisition MK through supply channels.
- c. Multiservice: Instructions shall be included for multiservice modifications.
- d. MAP/MAS Countries: Instructions shall be provided for MAP/MAS countries.

Table 4-1. Parts List for Installation of Radio Set AN/VRC-87/88/90 Series

NSN	ITEM DESCRIPTION AND PART NUMBER	QUANTITY IN MK	SMR CODE	FIGURE, ITEM NO.
5985-01-353-4943	Antenna, Vehicular AS-3916/VRC (A3207487-1)	1	PAOOFA	4-1, 2
5305-00-847-1159	Screw, Cap, Hexagon (3/8-16 x 1 3/4 in) MS35307-365	4	PAOZZA	
5310-00-913-8881	Nut, Hexagon (3/8-16 in) MS51971-3 (Not Used)	4	PAOZZA	
5310-00-061-1258	Washer, Lock, Internal/External-Toothed (3/8 in) MS45904-76 (4 Not Used)	8	PAOZZA	
5310-00-889-2527	Washer, Lock, Internal/External-Toothed (5/16 in) MS45904-72 (Not Used)	2	PAOZZA	
5306-00-225-9086	Bolt, Machine (5/16-24 x 5/8 in) MS90726-31 (Not Used)	1	PAOZZA	
5330-01-205-2864	Gasket (A3013655-1) (Not Used)	1	PAOZZA	
4010-01-381-1521	Wire Rope Assembly (A3207523-1)	1	PAOZZA	
5975-01-188-8873	Mounting Base, Electrical Equipment MT-6352/VRC (A3013367-1)	1	PAOOFA	4-1, 1
5306-00-225-9089	Bolt, Machine (5/16-24 x 1 in) MS90726-34	5	PAOZZA	
5310-00-889-2527	Washer, Lock, Internal/External-Toothed (5/16 in) MS45904-72 (5 Not Used)	10	PAOZZA	
5310-00-880-7746	Nut, Hexagon (5/16 - 24 in) MS51968-5 (Not Used)	5	PAOZZA	
5995-01-225-0503	Cable Assembly, Power, Electrical CX-13306/VRC (5 FT, 0 IN) (A3014043-6)	1	PAOZZA	
5995-01-219-7030	Cable Assembly, Radio Frequency CG-3855/VRC (7 FT, 0 IN) (A3014031-3)	1	PAOZZA	4-1, 7
5995-01-303-4951	Cable Assembly, Special Purpose, Electrical CX-13313/VRC (2 FT, 7 IN) (A3018360-1)	1	PAOZZA	4-1, 8
5995-01-227-0473	Cable Assembly, Special Purpose, Electrical CX-13300/VRC (4 FT, 0 IN) (A3014044-6)	1	PAOZZA	4-1,9
	Bracket, Angle (A3014090-1)	1	XBOZZA	4-1, 5
5340-00-809-1490	Clamp, Loop (1/4-1/4 in) MS21333-98	1	PAOZZA	
5340-00-400-0002	Clamp, Loop (1 1/4-1/4 in) MS9350-19	2	PAOZZA	
5310-00-732-0558	Nut, Plain, Hexagon (3/8-16 in) MS51967-8	8	PAOZZA	4-1, 4
	Plate, Mounting, Flat (A3014088-1)	2	XBOZZA	

**Table 4-1. Parts List for Installation of Radio Set AN/VRC-87/88/90 Series.** Continued

NSN	ITEM DESCRIPTION AND PART NUMBER	QUANTITY IN MK	SMR CODE	FIGURE, ITEM NO.
5305-00-068-0502	Screw, Cap, Hexagon (1/4-20 x 3/4 in) MS90725-6	3	PAOZZA	4-1, 3
5305-00-269-3211	Screw, Cap, Hexagon (3/8-16 x 1 in) MS90725-60	11	PAOZZA	
5975-00-111-3208	Shelf, Electrical Equipment (A3014087-1)	1	XBOZZA	
5310-00-061-1258	Strap, Tiedown, Electrical Components MS3367-5-9	5	PAOZZA	
5310-00-061-1258	Washer, Lock, Internal/External-Toothed (3/8 in) MS45904-76	19	PAOZZA	
5310-00-582-5965	Washer, Lock (1/4 in) MS35338-44	3	PAOZZA	



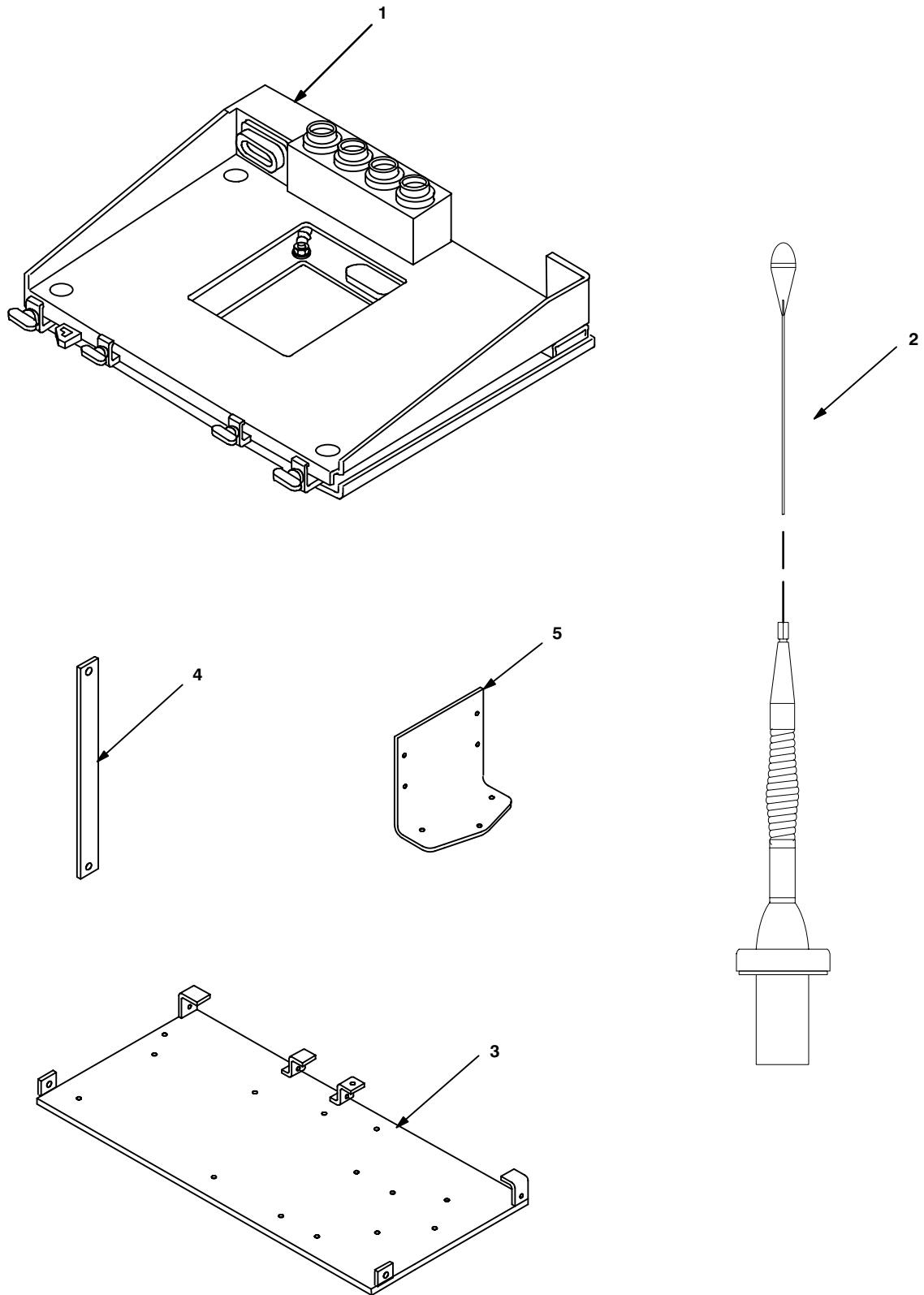

Figure 4-1 (1). MK Illustrated Parts List

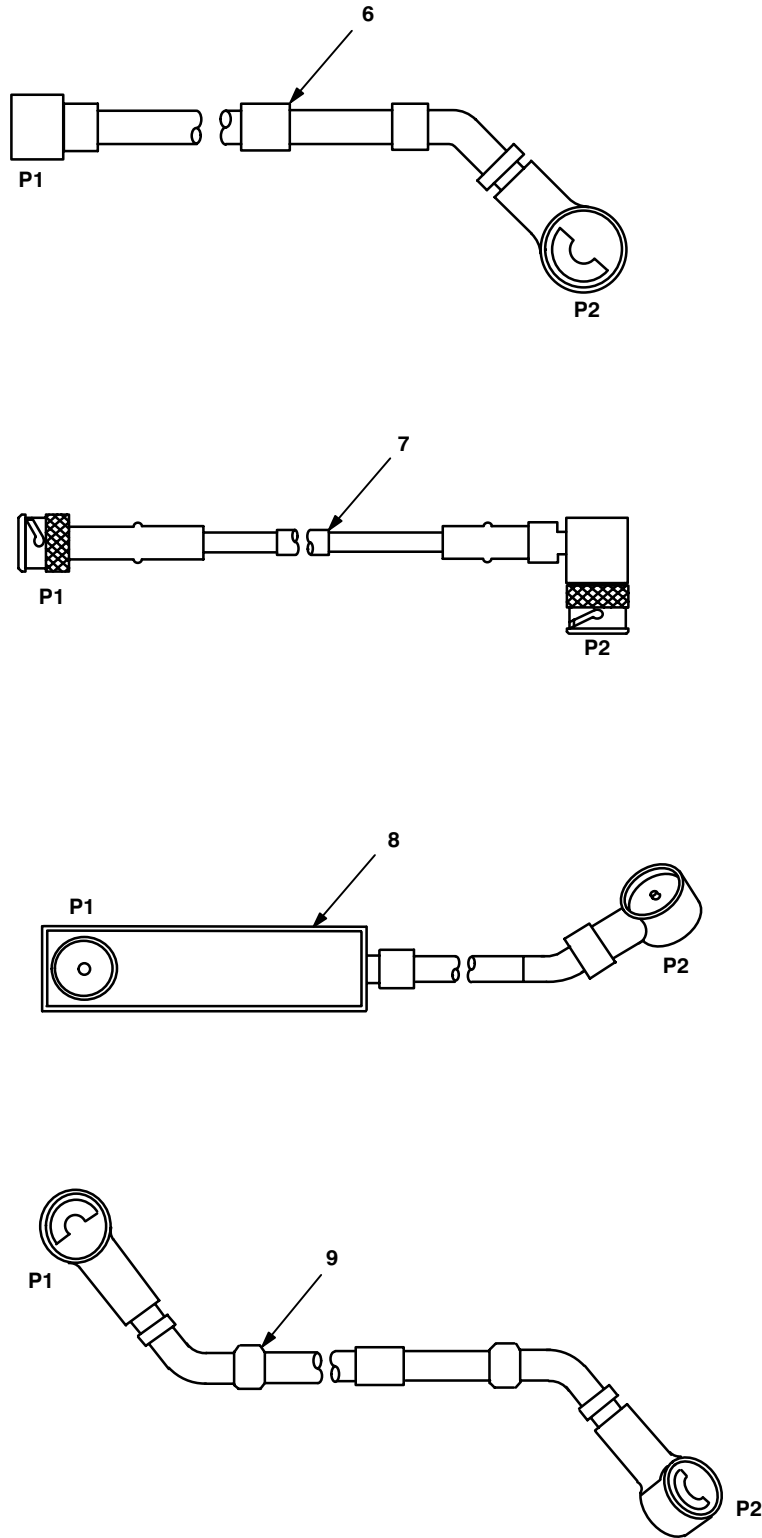

Figure 4-1 (2). MK Illustrated Parts List. Continued

**4.3.3 Consumable Materials.** The table below lists materials required for installation but not supplied with MK.

NSN	NOMENCLATURE
8040-00-117-8510	Adhesive-Sealant, Clear, RTV
6850-00-880-7616	Silicone Compound, MIL-S-8660
8030-00-292-1102	Conductive Anti-seize Compound

**4.4 Tools and Test, Measurement, and Diagnostic Equipment (TMDE) Required.** The following tools and TMDE are needed for installation.

NOMENCLATURE	NSN	QUANTITY
Radio Set*		1
Electric Grinder or Equivalent		1
Pocket Knife, Electrician's	5110-00-240-5943	1
Screwdriver, No. 2 Point Phillips, 4 in	5120-00-234-8913	1
Screwdriver, 1/4 in Flatblade, 4 in	5120-00-222-8852	1
Pliers, Round Nose	5120-00-240-6172	1
Pliers, Diagonal Cutting	5110-00-965-0974	1
Wrench, Open/Box: 7/16 in	5120-00-228-9505	1
1/2 in	5120-00-228-9506	1
9/16 in	5120-00-228-9507	1
Handle, Socket Wrench	5120-00-240-5364	1
Socket: 7/16 in	5120-00-227-6703	1
1/2 in	5120-00-237-0977	1
9/16 in	5120-00-227-6704	1

\* Use radio issued with your vehicle if available.

5. INSTALLATION PROCEDURES.

This section describes where and how to install MK items in the vehicle. See figure 5-1 for an overall view of where vehicular MK equipment, as well as radio components, typically will be installed. When installing MK equipment, be sure to read and follow instructions and illustrations carefully.

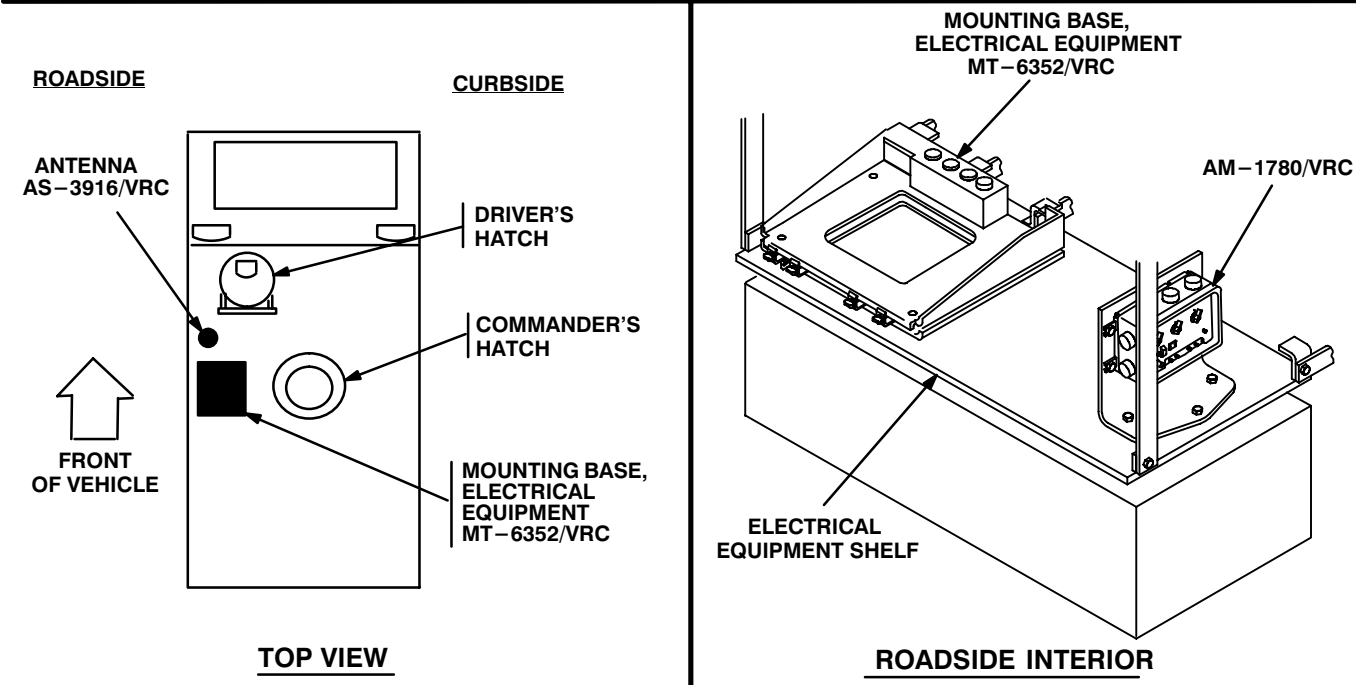
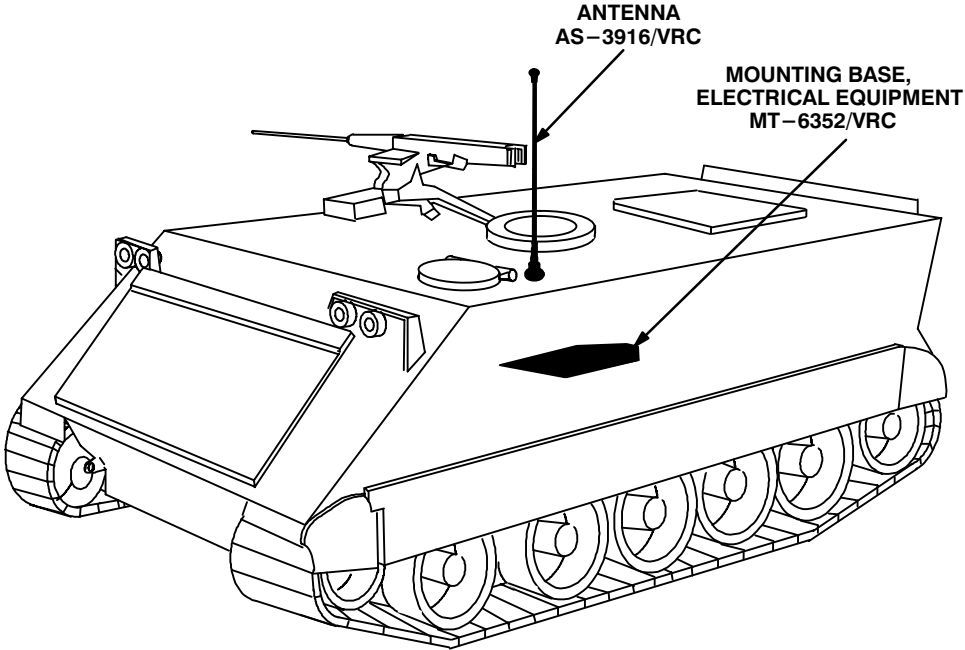

Figure 5-1 (1). MK and Radio Installation: MK Equipment Locations

5. INSTALLATION PROCEDURES.

INSTALLATION  
FOR  
AN/VRC-87/88/90 Series

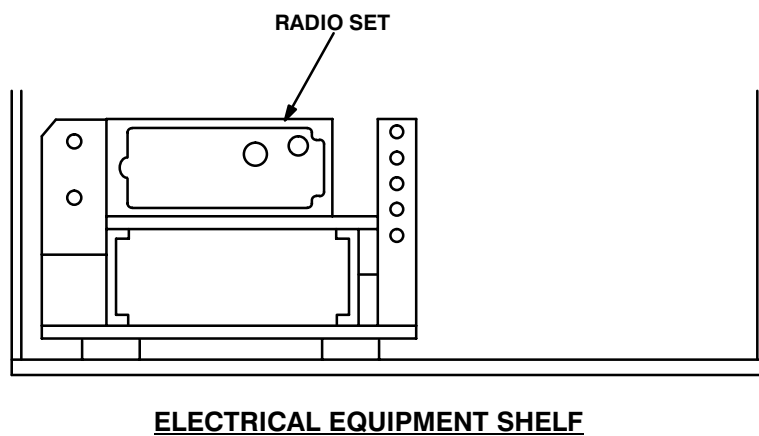
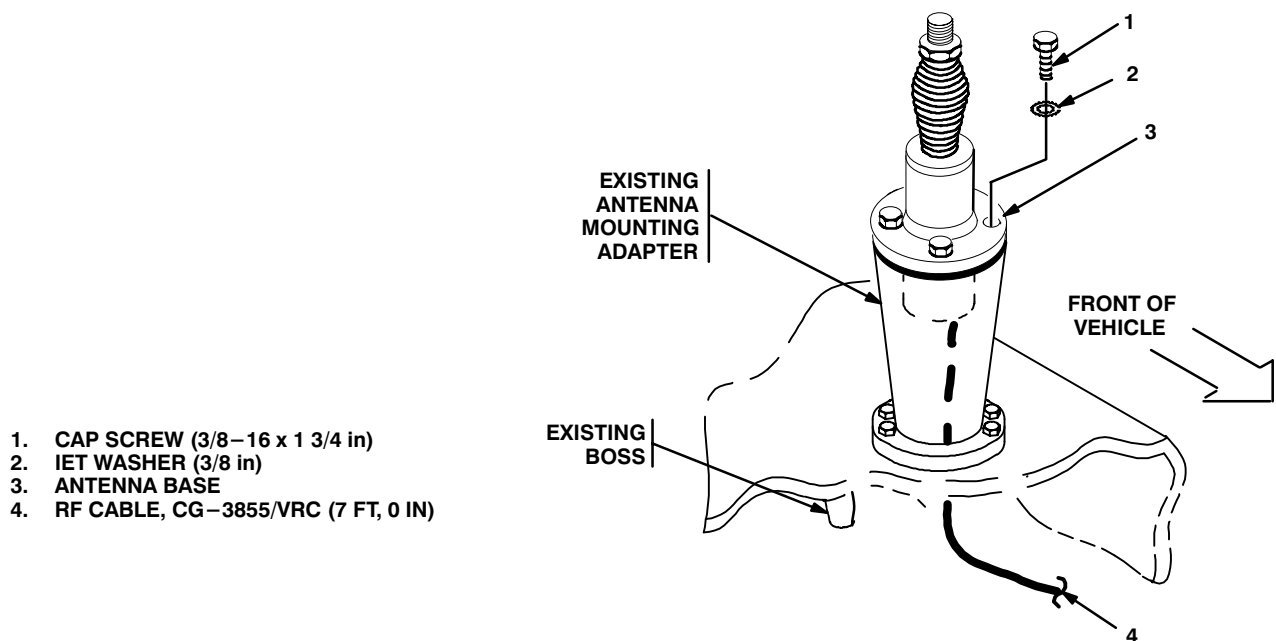

Figure 5-1 (2). MK and Radio Installation: Radio Equipment Locations

**5.1 Installation of Antenna AS-3916/VRC (antenna).**

**5.1.1 Installation of Antenna Base.** Use the following procedures to install antenna base. See figure 5-1 (1) for location. Remove ground strap from antenna base(s).

ITEM	ACTION	REMARKS
<b>NOTE</b>		
Apply a thin coat of adhesive-sealant to both sides of each internal/external-toothed (IET) washer during installation, and to the area of contact where IET washer is to be placed.		
a. Existing antenna mounting adapter.	Remove the paint (1" strip) for 360° centered around the four mounting holes. Clean the paint removed areas and apply a thin coat of conductive anti-seize compound.	Tools: Electric grinder or equivalent.
b. RF cable (4) connector P1.	From inside vehicle, insert through antenna mounting adapter to exterior of vehicle; then connect and secure to antenna base (3) connector J1. See Figure 5-2	
c. Antenna base (3).	Place on top of antenna mounting adapter and align mounting holes.	
d. Four cap screws (1) and four internal/external-toothed (IET) washers (2).	Install and secure to antenna base (3) and existing antenna adapter.	Tools: 9/16 in socket.
e. Antenna base (3) and antenna mounting adapter.	Apply a bead of adhesive-sealant/silicon compound 360° around the seam between antenna base (3) and antenna adapter.	Tools: 1/2 in socket.



**Figure 5-2. Antenna Base Installation: Front Roadside**

**5.1.2 Installation of Top Antenna Assembly.** The top portion of the antenna includes a lower element and an upper element (with installed cap). Use the following procedure to assemble, install and tie down all antennas.

ITEM	ACTION	REMARKS
a. Antenna element (1).	Install and secure to antenna base (2).	
b. Wire rope assembly	Attach clip to antenna element (1). Tie rope to vehicle to position antenna in desired location. See Figure 5-3, Detail A.	

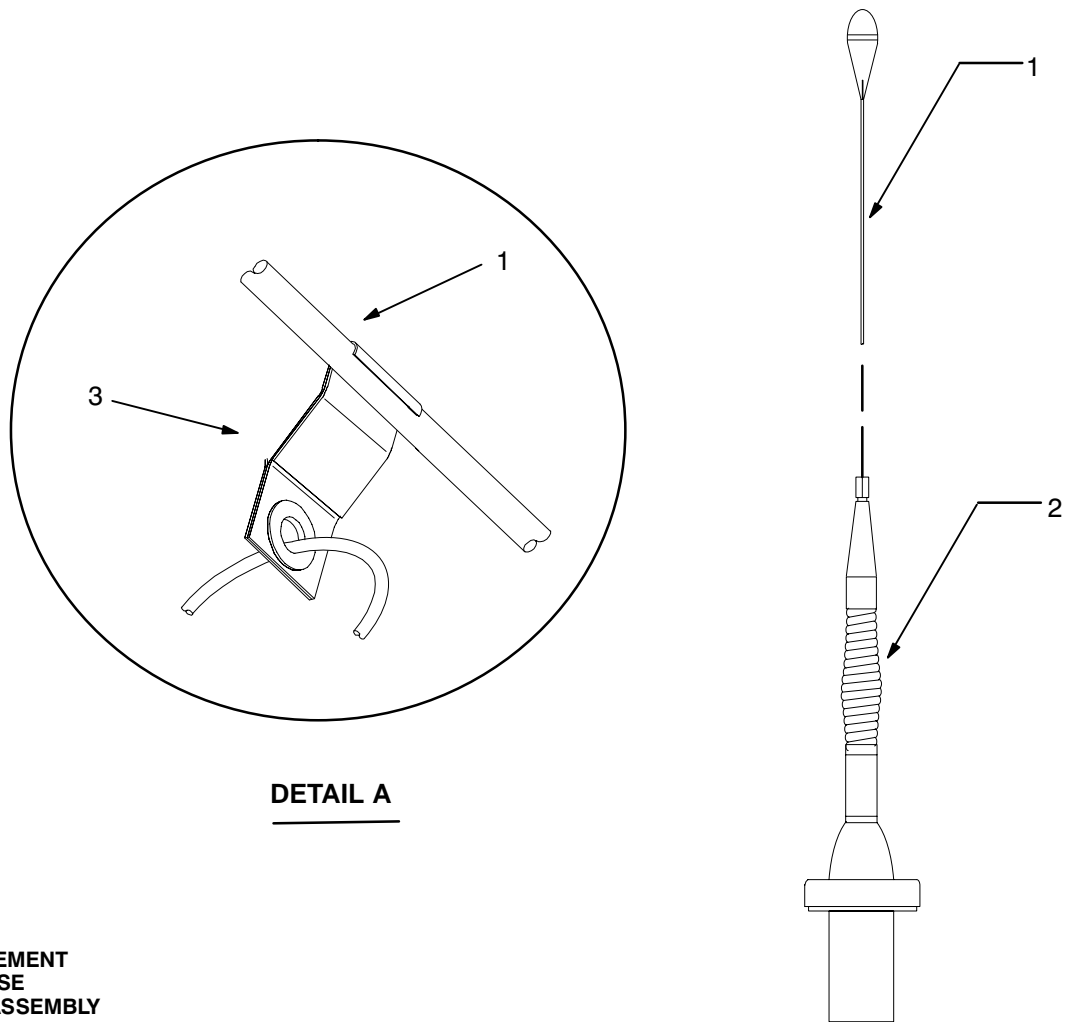

**Figure 5-3. Top Antenna Assembly Installation**

**5.2 Installation of Electrical Equipment Shelf.** See figure 5–1 (1) for location.

ITEM	ACTION	REMARKS
<b>NOTE</b>		
Apply a thin coat of adhesive–sealant to both sides of each internal/external–toothed (IET) washer during installation, and to the area of contact where IET washer is to be placed.		
a. Electrical equipment shelf (1) four rear shelf mounts and four existing wall mounts.	Remove the paint (1” square) on the out–side of the four mounting holes in rear shelf mounts and four existing wall mounts. Clean the paint removed areas and apply a thin coat of conductive anti–seize compound.	Tools: Electric grinder or equivalent.
b. Electrical equipment shelf (1) two front shelf mounts, two flat mounting plates (5) and two existing wall/roof mounts.	Remove the paint (1” square) arpund the mating side of two mounting holes in front shelf mounts, two mounting holes in wall/roof mounts, and four mounting holes in flat mounting plates (5). Clean the paint removed areas and apply a thin coat of conductive anti–seize compound.	Tools: Electric grinder or equivalent.
c. Angle bracket (6) electrical equipment shelf (1), and existing AM–1780/VRC.	Remove a 1” square area of paint on the underside of angle bracket around three mounting holes. Remove a 1” square area of paint on the electrical equipment shelf around the existing mounting holes that mate with three mounting holes of angle bracket (6). Remove the paint (1” square) around the mating side of four AM–1780/VRC mounting holes in angle bracket (6) and four flanges on AM–1780/VRC. Clean the paint removed areas and apply a thin coat of conductive anti–seize compound (CASC).	Tools: 9/16 in socket and 9/16 open/box wrench.
d. AM–1780/VRC and existing mounting hardware.	Install and secure to angle bracket (6).	
e. Angle bracket (6), three cap screws (4), and three internal/external–toothed (IET) washers (3).	Install and secure to electrical equipment shelf (1) mounting holes.	
f. Electrical equipment shelf (1).	Align mounting holes in four rear shelf mounts with holes in existing wall mounts.	
g. Four cap screws (4), eight internal/external–toothed (IET) washers (3), and four nuts (2).	Install and secure to rear shelf mounts and wall mounts.	Tools: 9/16 in socket and 9/16 in open/box wrench.
h. Two flat mounting plates (5), four cap screws (4), eight internal/external–toothed (IET) washers (3), amd four nuts.	Install and secure to front shelf mounts of electrical equipment shelf (1) and existing wall/roof mounts.	Tools: 9/16 in socket and 9/16 in open/box wrench.



5.2 Installation of Electrical Equipment Shelf. Continued.

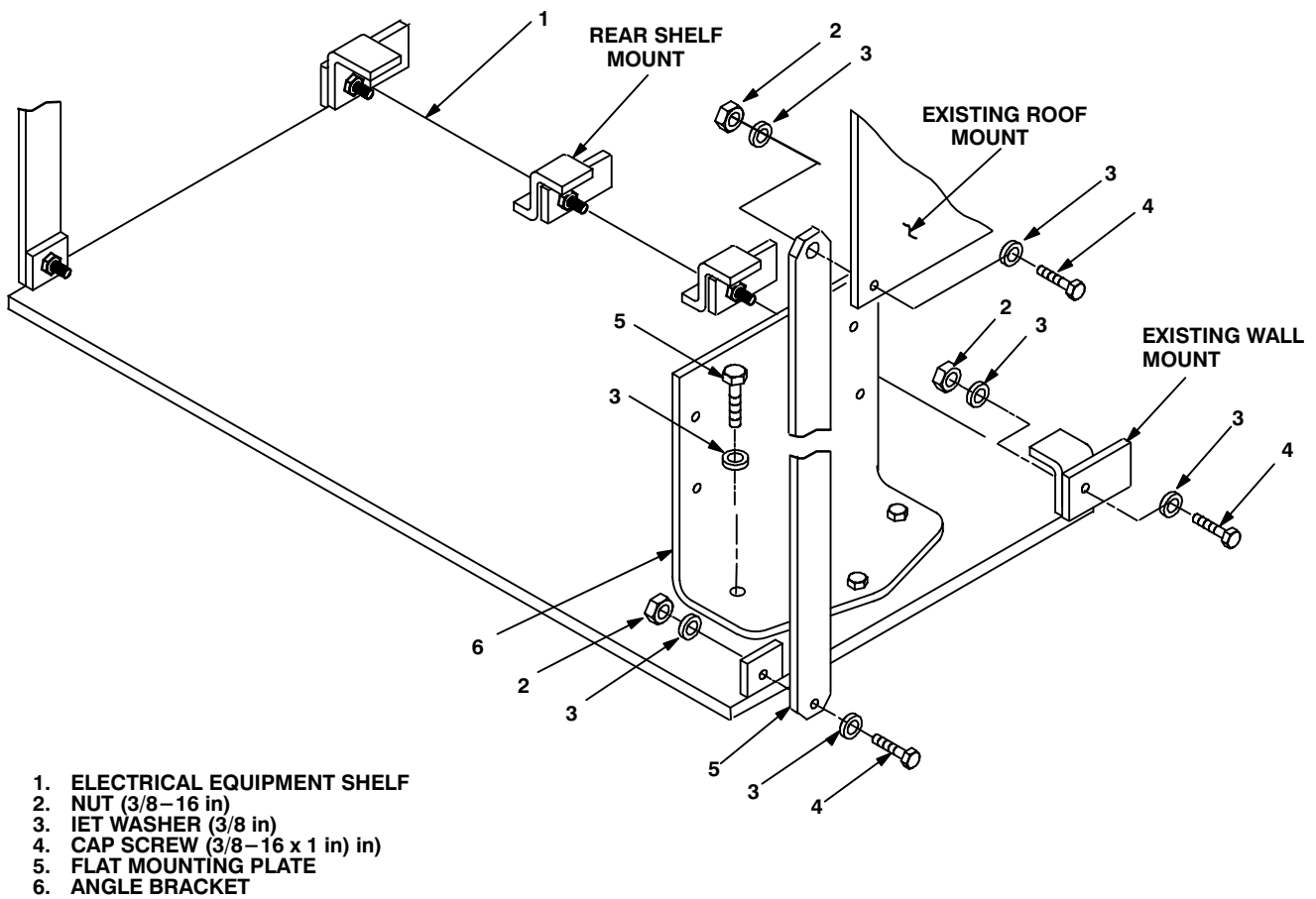

Figure 5-4. Electrical Equipment Shelf Assembly and Installation

**5.3 Installation of Mounting Base, Electrical Equipment MT–6352/VRC (mounting base).** Remove and retain attaching bag of 5/16 in mounting hardware for installation. To insure good electrical grounding, any rust, corrosion or paint around mounting holes in mounting plate should be removed before installing the mounting base. See Figure 5–1(1) for location; then see Figure 5–5 and perform the following steps

ITEM	ACTION	REMARKS
<b>NOTE</b>		
Apply a thin coat of adhesive–sealant to both sides of each internal/external–toothed (IET) washer during installation, and to the area of contact where IET washer is to be placed.		
a. Mounting base (1) and electrical equipment shelf (2).	Remove a 2” square area of paint on the underside of the mounting base (1) around left front and rear mounting holes. Remove a 2” square area of paint on the electrical equipment shelf (2) around the existing mounting holes that mate with front and rear mounting holes of mounting base (1). Clean the paint removed areas and apply a thin coat of CASC.	Tools: Electric grinder or equivalent.
b. Mounting base (1).	Place on electrical equipment shelf (2). See Figure 5–5.	
c. Two outer thumbscrews (3).	Turn ccw until both sets of threads have cleared center of holes.	
d. Mounting base (1).	Aline four holes and rear slot with matching hole pattern in shelf (2).	Tools: 1/2 in socket and 1/2 in open/box wrench.
e. Five machine bolts (6) and five internal/external–toothed (IET) washers (5).	Install and secure to mounting base (1) and shelf (2).	
f. Two outer thumbscrews (3).	Tighten and secure to rim clenching clamps (4) and mounting base (1).	

5.3 Installation of Mounting Base, Electrical Equipment MT-6352/VRC (mounting base). Continued. .

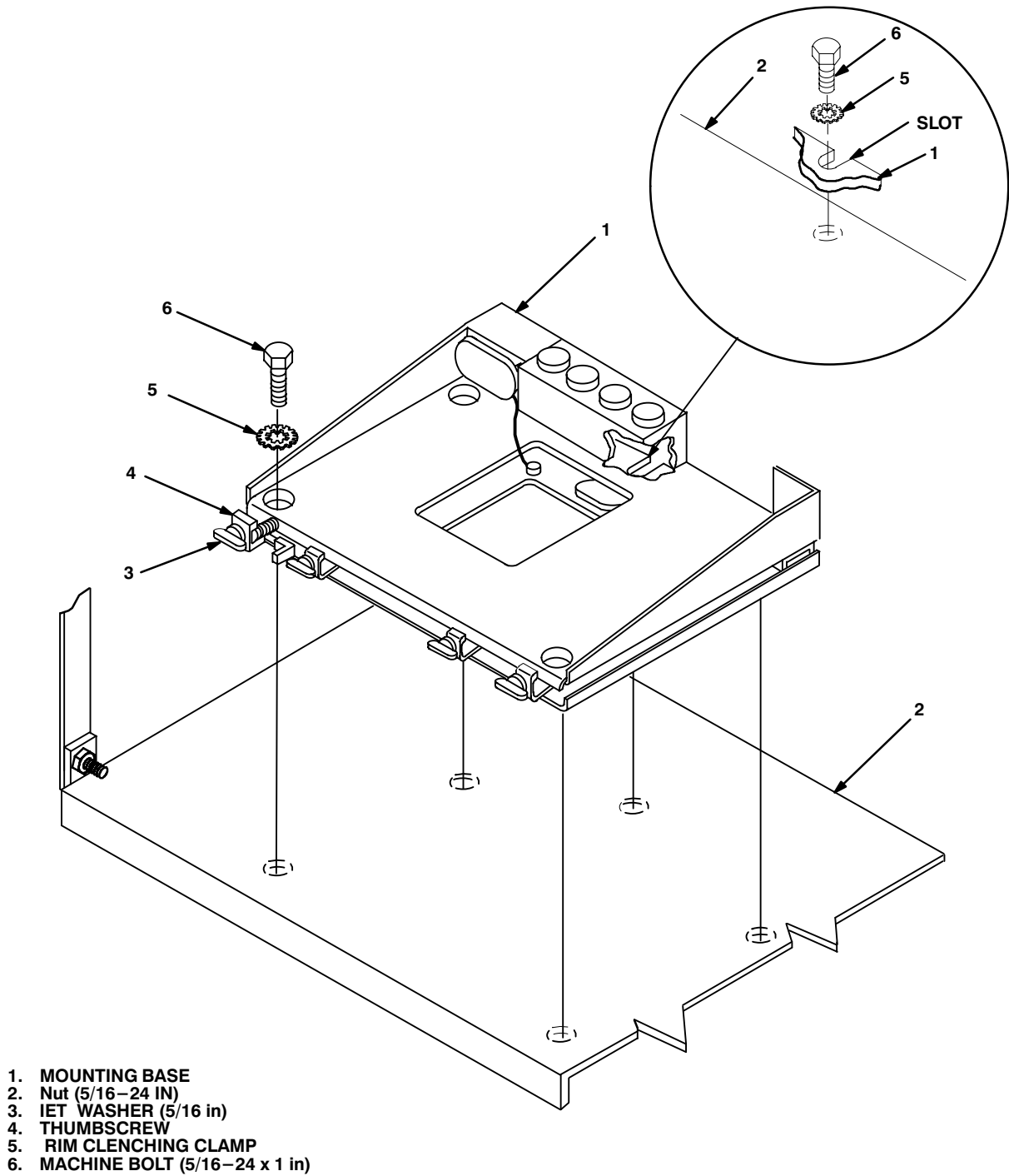

Figure 5-5. Mounting Base Installation: Roadside

**5.4 Installation of Cables.** To accomplish the installation, leave loop clamps and tiedown straps loose enough to adjust cable slack and allow easy adjustment of equipment. When installation is complete, tighten and secure clamps and tiedown straps.

**WARNING**

Make sure vehicle power source is positioned OFF or disconnected before installing cables.

ITEM	ACTION	REMARKS
a. RF cable (4).	From antenna base (2), route along rear of electrical equipment shelf (6) to left side of mounting base (7). See figure 5–6.	
b. RF cable (4) connector P2.	Position on top of mounting base (7).	
c. Loop clamp (8), cap screw (1/4–20 x 3/4 in), and lock washer (1/4 in).	Wrap clamp around RF cable (4); then install to tapped hole in shelf. See figure 5–6 for location(s).	Tools: 7/16 in socket or 7/16 in open/box wrench.
d. SP cable (5) connector P1.	Connect and secure to AM–1780/VRC connector J501. See figure 5–6.	
e. SP cable (5).	Route along electrical equipment shelf (6) to rear of mounting base (7).	
f. SP cable (5) connector P2.	Connect and secure to SP cable (9) connector P1. See figure 5–6, detail A.	
g. SP cable (9) connector P2.	Connect and secure to mounting base (7) connector J3.	
h. Power cable (3) connector P1.	Connect and secure to power Bendix connector. See figure 5–6.	
i. Power cable (3).	Route down roadside wall to electrical equipment shelf (6).	
j. Two loop clamps (1), two cap screws (1/4–20 x 3/4 in) and two lock washers (1/4 in).	Wrap clamps around power cable (3), SP cable (5) and RF cable (4); then install to tapped holes in electrical equipment shelf (6). See figure 5–6 for location(s).	Tools: 7/16 in socket.
k. Power cable (3) connector P2.	Connect and secure to mounting base (7) connector J1. See figure 5–6.	

5.4 Installation of Cables. Continued.

1. LOOP CLAMP (1 1/4-1/4 in)  
CAP SCREW (1/4-20 x 3/4 in)  
LOCK WASHER (1/4 in)
2. ANTENNA BASE
3. POWER CABLE, CX-13306/VRC (5 FT, 0 IN)
4. RF CABLE, CG-3855/VRC (7 FT, 0 IN)
5. SP CABLE, CX-13300/VRC (4 FT, 0 IN)
6. ELECTRICAL EQUIPMENT SHELF
7. MOUNTING BASE
8. LOOP CLAMP (1/4-1/4 in)  
CAP SCREW (1/4-20 x 3/4 in)  
LOCK WASHER (1/4 in)
9. SP CABLE, CX-13313/VRC (2 FT, 7 IN)

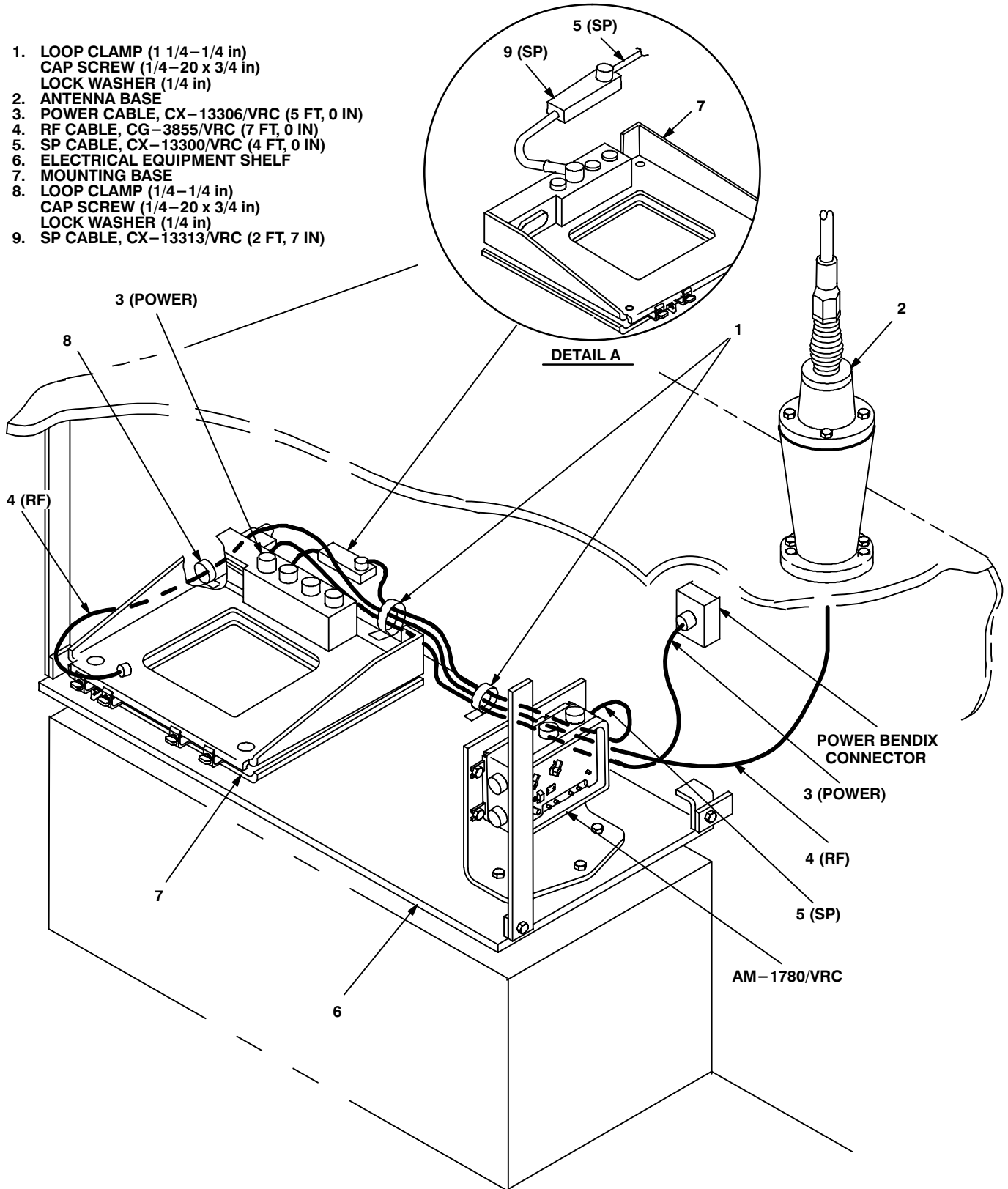
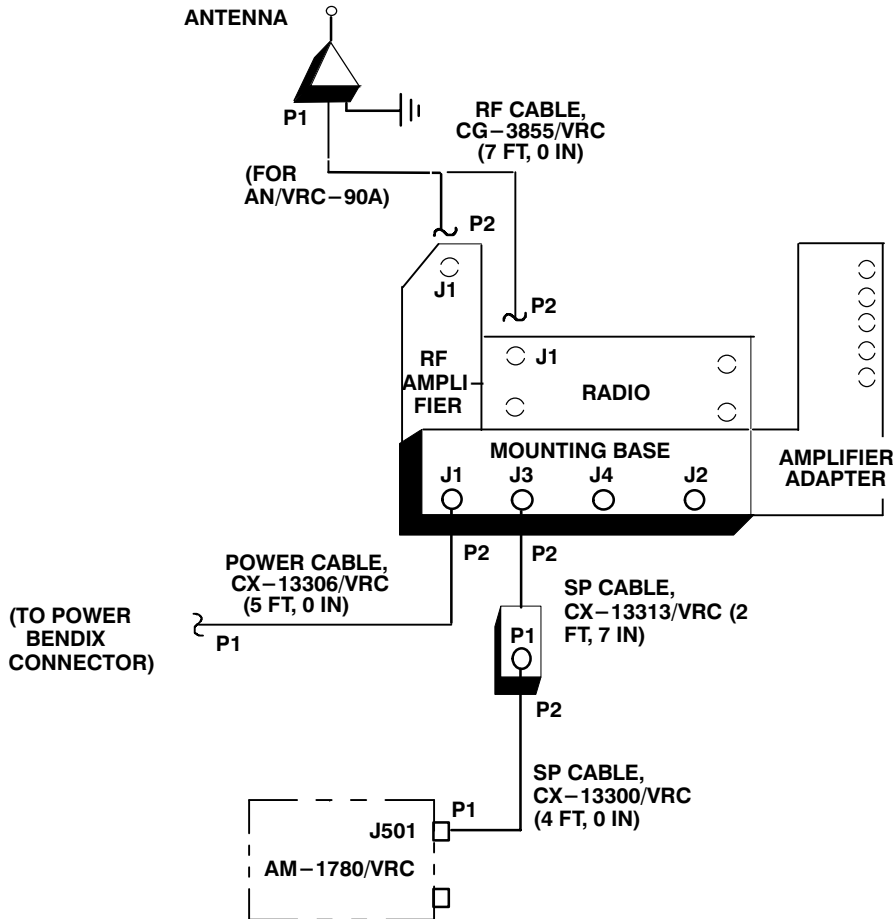

Figure 5-6. Cable Installation: Roadside Interior

**5.5 Post-Installation and Checkout.** After equipment is installed and cables are connected, perform the following steps.

ITEM	ACTION	REMARKS
a. Equipment.	Check for secure mounting. Check for loose parts, connectors and mounting hardware.	
b. Cables.	Check for proper installation and connection of cables. See figure 5-7 for cable connections. Unused cables should be stowed in appropriate place inside the vehicle.	
c. Loop clamps.	Check that all have been properly installed and tightened.	
d. Protective covers.	Insure that all installed cables are covered when not in use or connected.	
e. Radio issued with vehicle.	Install and connect cables. See TM 11-5820-890-20-1 or TM 11-5820-890-20-4 for installation and Operational (OP) Check instructions.	
f. MK line replaceable units.	See TM 11-5820-890-20P for Repair Parts and Special Tools List (RPSTL) information.	

5.5 Post-Installation and Checkout. Continued



CABLE ASSEMBLY	FROM			TO		
	CABLE CONN.	UNIT	UNIT CONN.	CABLE CONN.	UNIT	UNIT CONN.
CX-13306/VRC (5 FT, 0 IN)	P2	Mounting base	J1	P1	Power Bendix connector	
CX-13300/VRC (4 FT, 0 IN)	P2	CX-13313/VRC (2 FT, 7 IN)	P1	P1	AM-1780/VRC	J501
CX-13313/VRC (2 FT, 7 IN)	P1	CX-13300/VRC (4 FT, 0 IN)	P2	P2	Mounting base	J3
CG-3855/VRC (7 FT, 0 IN)	P1	Antenna base	J1	P2	RF amplifier or radio	J1

Figure 5-7. Cable Diagram: For AN/VRC-87/88/90 Series.

5.6 Post-Installation and Checkout. Continued

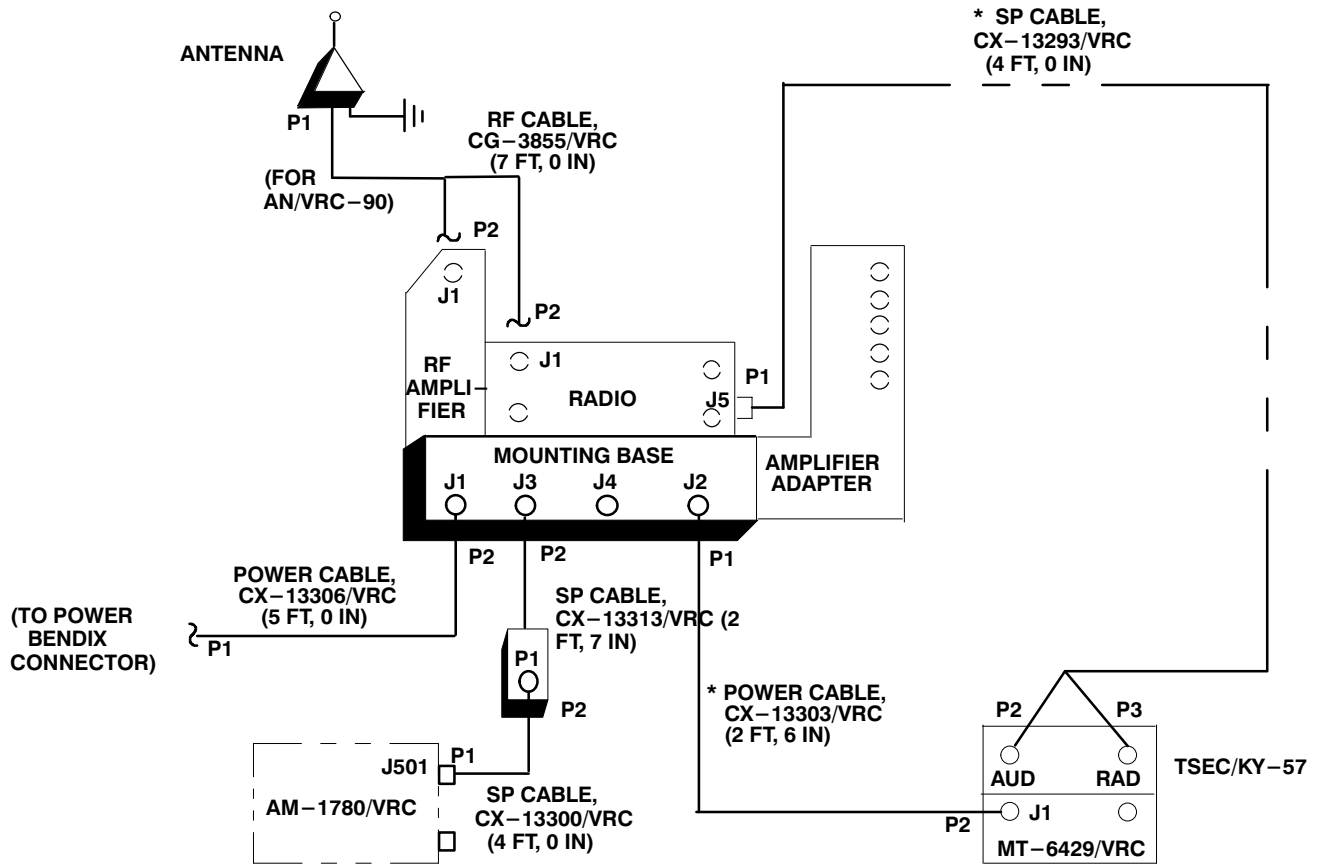

\* NOT SUPPLIED IN THIS MK.

CABLE ASSEMBLY	FROM			TO		
	CABLE CONN.	UNIT	UNIT CONN.	CABLE CONN.	UNIT	UNIT CONN.
CX-13306/VRC (5 FT, 0 IN)	P2	Mounting base	J1	P1	Power Bendix connector	
CX-13300/VRC (4 FT, 0 IN)	P2	CX-13313/VRC (2 FT, 7 IN)	P1	P1	AM-1780/VRC	J501
CX-13313/VRC (2 FT, 7 IN)	P1	CX-13300/VRC (4 FT, 0 IN)	P2	P2	Mounting base	J3
CG-3855/VRC (7 FT, 0 IN)	P1	Antenna base	J1	P2	RF amplifier or radio	J1
* CX-13303/VRC (2 FT, 6 IN)	P1	Mounting base	J2	P2	MT-6429/VRC	J1
* CX-13293/VRC (4 FT, 0 IN)	P1	Radio	J5	P2 P3	TSEC/KY-57	AUD RAD

\* Not supplied in this MK.

Figure 5-7 (2). Cable Diagram: For AN/VRC-87/88/90



## APPENDIX A

### REFERENCES

---

AMDF	Army Master Data File (Microfiche)
AR 710-2	Supply Policy Below the Wholesale Level as Contained in Unit Supply UPDATE
AR 725-50	Requisitioning, Receipt and Issuing System in UPDATE
DA Pam 25-30	Consolidated Index of Army Publications (Microfiche)
DA Pam 710-2-1	Using Unit Supply System Manual Procedures as Contained in Unit Supply UPDATE
SB 11-131	Vehicular Radio Sets and Authorized Installations (SINCGARS)
TM 11-5820-890-10-1	Operator's Manual (ICOM Radio Sets)
TM 11-5820-890-10-3	Operator's Manual (Non-ICOM Radio Sets)
TM 11-5820-890-20-1	Unit Maintenance Manual (ICOM Radio Sets, Vol. 1)
TM 11-5820-890-20-2	Unit Maintenance Manual (ICOM Radio Sets, Vol. 2)
TM 11-5820-890-20-3	Unit Maintenance Manual handbook (ICOM Radio Sets)
TM 11-5820-890-20-4	Unit Maintenance Manual (Non-ICOM Radio Sets)
TM 11-5820-890-20P	Repair Parts and Special Tools List

By Order of the Secretary of the Army:

Official:

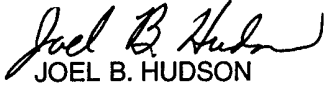

JOEL B. HUDSON  
*Administrative Assistant to the  
Secretary of the Army*

9916723

**ERIC K. SHINSEKI**  
*General, United States Army  
Chief of Staff*

**DISTRIBUTION:**

To be distributed in accordance with the initial distribution number (IDN) 369619 requirements for TB 11-5820-890-20-54.

# SOMETHING WRONG WITH THIS PUBLICATION



THEN ... JOT DOWN THE INFO ABOUT IT ON THIS FORM. CAREFULLY TEAR IT OUT. FOLD IT AND DROP IT IN THE MAIL.

FROM: (PRINT YOUR UNIT'S COMPLETE ADDRESS)  
 Commander  
 Stateside Army Depot  
 ATTN: AMSTA-US  
 Stateside, NJ 07703-5007

DATE SENT  
 10 July 1995

PUBLICATION NUMBER <b>TM 11-5840-340-12</b>	PUBLICATION DATE <b>23 Jan 74</b>	PUBLICATION TITLE <b>Radar Set AN/PRC-76</b>
--	--------------------------------------	---

BE EXACT PIN-POINT WHERE IT IS				IN THIS SPACE TELL WHAT IS WRONG AND WHAT SHOULD BE DONE ABOUT IT:
PAGE NO	PARA-GRAPH	FIGURE NO	TABLE NO	
2-25	2-28			<p>Recommend that the installation antenna alignment procedure be changed throughout to specify a 20 IFF antenna lag rather than 10</p> <p>REASON: Experience has shown that with only a 10 lag, the antenna servo system is too sensitive to gusting in excess of 25 knots, and has a tendency to rapidly accelerate and decelerate as it hunts, causing strain to the drive train. Hunting is minimized by adjusting the lag to 20 without degradation of operation.</p>
3-10	3-3		3-1	<p>Item 5, Functional column. Change <input type="checkbox"/> 2 dB" to <input type="checkbox"/> 3 dB".</p> <p>REASON: The adjustment procedure for the TRANS POWER FAULT indicator call for a 3 dB (500 watts) adjustment to light the TRANS POWER FAULT indicator.</p>
5-6	5-8			<p>Add new step f.1 to read, <input type="checkbox"/> Replace cover plate removed in step d above."</p> <p>REASON: To replace the cover plate.</p>
		FO-3		<p>ZONE C 3. On J1-2, change <input type="checkbox"/> +24 VDC" to <input type="checkbox"/> +5 VDC".</p> <p>REASON: This is the output line of the 5 VDC power supply. +24 VDC is the input voltage.</p>

SAMPLE

TEAR ALONG DOTTED LINE

PRINTED NAME, GRADE OR TITLE AND TELEPHONE NUMBER <b>SSG I. M. DeSpirito 999-1779</b>	SIGN HERE 
--	---------------

# SOMETHING WRONG WITH THIS PUBLICATION



THEN ... JOT DOWN THE INFO ABOUT IT ON THIS FORM. CAREFULLY TEAR IT OUT. FOLD IT AND DROP IT IN THE MAIL.

FROM: (PRINT YOUR UNIT'S COMPLETE ADDRESS)

DATE SENT

PUBLICATION NUMBER

PUBLICATION DATE

PUBLICATION TITLE

BE EXACT PIN-POINT WHERE IT IS

IN THIS SPACE TELL WHAT IS WRONG AND WHAT SHOULD BE DONE ABOUT IT:

PAGE NO	PARA-GRAPH	FIGURE NO	TABLE NO

TEAR ALONG DOTTED LINE

PRINTED NAME, GRADE OR TITLE AND TELEPHONE NUMBER

SIGN HERE

FILL IN YOUR  
UNIT'S ADDRESS

FOLD BACK

DEPARTMENT OF THE ARMY



OFFICIAL BUSINESS

PLEASE  
AFFIX  
STAMP  
POSTAGE  
REQUIRED

TEAR ALONG DOTTED LINE

**Commander**  
**U.S. Army Communications-Electronics Command**  
**and Fort Monmouth**  
**ATTN: AMSEL-LC-LEO-D-CS-CFO**  
**Fort Monmouth, New Jersey 07703-5000**



FOLD BACK

